

THE SPA LIFT™ - 24V BATTERY

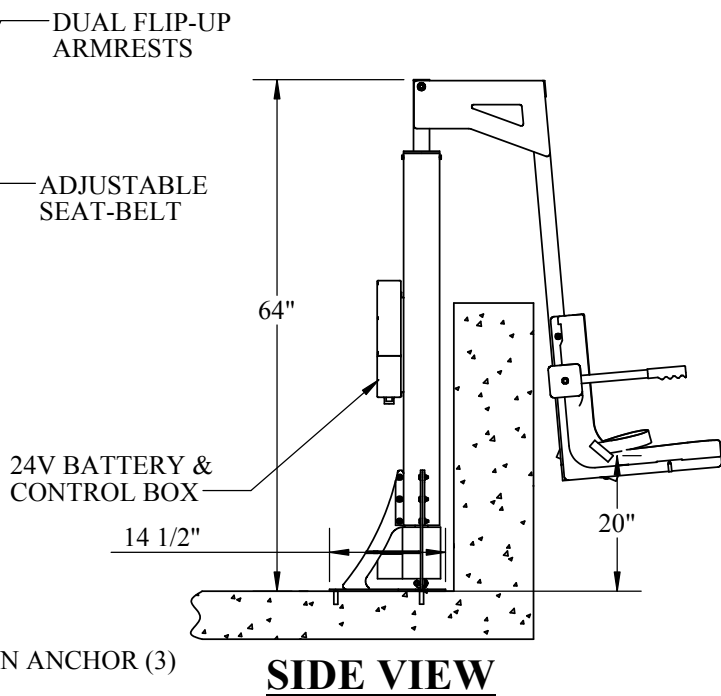

SPECIFICATIONS

THE AQUA CREEK SPA LIFT - BATTERY SHALL BE A 24 VOLT, ELECTRICALLY ACTUATED ABOVE GROUND HOT TUB OR SPA LIFT. THE LIFT SHALL BE POWERED BY A 24V RECHARGABLE BATTERY CAPABLE OF BEING REMOVED FOR CHARGING. THE LIFT SHALL BE OF STAINLESS STEEL CONSTRUCTION WITH A LIFTING CAPACITY OF 400 LBS. THE LIFT SHALL BE CAPABLE OF CLEARING A 40" HIGH, 10" WIDE WALL. THE LIFT SHALL BE MOUNTED TO THE DECK AT THREE ANCHOR POINTS. THE LIFT SHALL BE POWERED UP AND DOWN, AND SHALL MANUALLY ROTATE 360° IN EITHER DIRECTION. THE SPA LIFT -BATTERY SHALL INCLUDE AN ADJUSTABLE SEAT-BELT AND DUAL FLIP-UP ARMRESTS. A 5-YEAR LIMITED WARRANTY IS STANDARD.

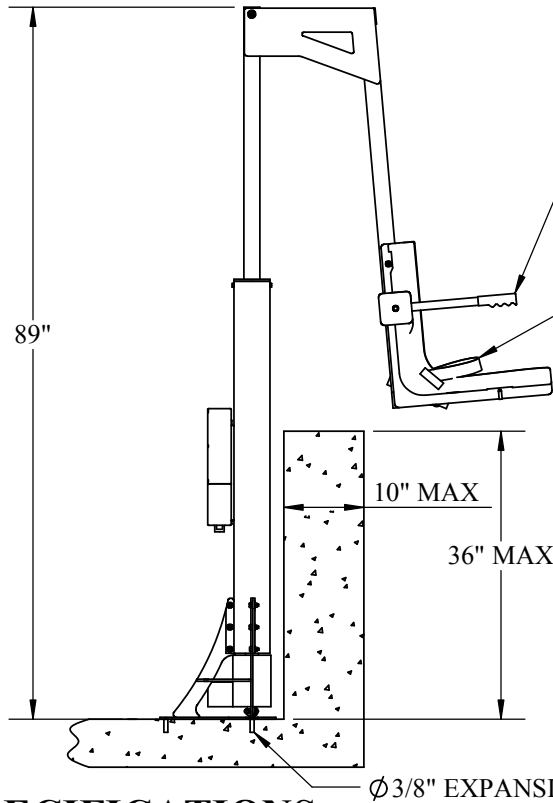
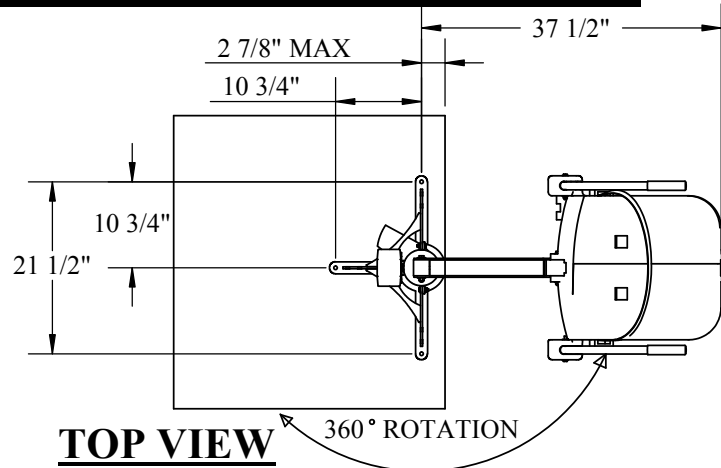
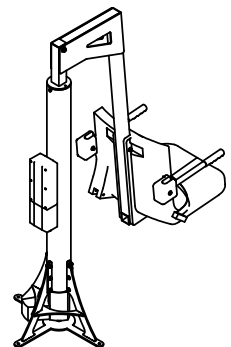

- BATTERY: 24VDC RECHARGABLE BATTERY PACK
- MAIN HOUSING: Ø4" SCH-10 TYPE 304 STAINLESS STEEL PIPE
- CHAIR ARM: 2" SQUARE TUBE, TYPE 304 STAINLESS STEEL
- ANCHORS: 3/8" DROP-IN EXPANSION ANCHORS (3) TYPE 304 STAINLESS STEEL
- FINISH: UV RESISTANT POLYESTER POWDER COATING

3015 W. RAILROAD ST. #8
MISSOULA, MT 59808
(406) 549-0769
FAX (406) 549-2602

NOTE:
*SPECIFICATIONS ARE SUBJECT TO CHANGE WITHOUT NOTICE
*ALL DIMENSIONS ARE IN INCHES



PRODUCT:	F-005PSL	
DWG #:	F-005PSL-1	
SCALE:	1:24	DATE: 09/10/06
DRAWN BY:	DSE	REVISION: B